



Michael A. Berardi
Director
Service Engineering Operations
Ford Customer Service Division

Ford Motor Company
P. O. Box 1904
Dearborn, Michigan 48121

March 5, 2013

TO: All U.S. Ford and Lincoln Dealers

SUBJECT: Safety Recall 13S01
Certain 2004 through 2007 Model Year Freestar and Monterey Vehicles Operated in
Corrosion States
3rd Row Seat Latch Striker Corrosion Repair

AFFECTED VEHICLES

Certain 2004 through 2007 model year Freestar and Monterey vehicles built at the Oakville Assembly Plant from Job #1 2004 through Job Last 2007 and originally sold in, or currently registered in the following states:

Connecticut	Iowa	Minnesota	Ohio	Wisconsin
Delaware	Maine	Missouri	Pennsylvania	
District of Columbia	Maryland	New Hampshire	Rhode Island	
Illinois	Massachusetts	New Jersey	Vermont	
Indiana	Michigan	New York	West Virginia	

Affected vehicles are identified in OASIS. In addition, for a list of vehicles assigned to your dealership, visit <https://web.fsavinlists.dealerconnection.com>. This information will be available on March 5, 2013.

REASON FOR THIS SAFETY RECALL

In some of the affected vehicles that are operated in high corrosion areas for an extended period, the sheet metal that supports the folding 3rd row seat latch strikers could experience corrosion and may compromise the mounting point for the forward portion of the 3rd row seat. Initially, this condition may result in seat movement when passengers sit on or put weight on the seat, or difficulty latching the front of the seat when in its seating position. If corrosion is severe, the seat latch strikers may become detached from the vehicle. The seat belts and the permanent mounting attachment at the rear of the seat are unaffected.

SERVICE ACTION

Dealers are to install new 3rd row seat latch striker mounting brackets which will re-locate the seat latch strikers away from the potentially corroded area. In addition, dealers are to install overlay panels in the exterior of the wheel wells to prevent the entry of water and corrosive elements. This service must be performed on all affected vehicles at no charge to the vehicle owner.

NOTE: For customers in non-corrosion areas whose Freestar or Monterey is not covered under this program but exhibits symptoms consistent with this condition, dealers can call the Special Service Support Center at 1-800-325-5621 to request the same service action.

OWNER NOTIFICATION MAILING SCHEDULE

Parts to repair this condition are currently not available in sufficient quantities to service all of the affected vehicles. Therefore, to ensure an ample supply of parts are available, owners of affected vehicles will be notified in multiple mailings. Mailings will begin the week of March 25, 2013, and are expected to be complete by April 30, 2013. Dealers should repair any affected vehicles that arrive at their dealership, whether or not the customer has received a letter.

PLEASE NOTE:

Federal law requires dealers to complete this recall service before a new vehicle is delivered to the buyer or lessee. Violation of this requirement by a dealer could result in a civil penalty of up to \$7,000 per vehicle. Correct all vehicles in your new vehicle inventory before delivery.

ATTACHMENTS

Attachment I: Administrative Information
Attachment II: Labor Allowances and Parts Ordering Information
Attachment III: Technical Information
Owner Notification Letter
Recall Reimbursement Plan

QUESTIONS & ASSISTANCE

Special Service Support Center (Dealer Assistance Only) 1-800-325-5621
Special Service Support Center (Parts Ordering) 1-800-207-2444

Sincerely,



Michael A. Berardi

Safety Recall 13S01

Certain 2004 - 2007 Model Year Freestar and Monterey Vehicles Operated in Corrosion States
3rd Row Seat Latch Striker Corrosion Repair

OASIS ACTIVATED?

Yes, OASIS will be activated on March 5, 2013.

FSA VIN LIST ACTIVATED?

Yes, FSA VIN list will be available through <https://web.fsavinlists.dealerconnection.com> on March 5, 2013. Owner names and addresses will be available by May 3, 2013.

NOTE: Your FSA VIN list may contain owner names and addresses obtained from motor vehicle registration records. The use of such motor vehicle registration data for any purpose other than in connection with this recall is a violation of law in several states, provinces, and countries. Accordingly, you must limit the use of this listing to the follow-up necessary to complete this recall.

STOCK VEHICLES

Use OASIS to identify any affected vehicles in your used vehicle inventory.

SOLD VEHICLES

- Owners of affected vehicles will be directed to dealers for repairs.
- Correct other affected vehicles identified in OASIS which are brought to your dealership.

TITLE BRANDED / SALVAGED VEHICLES

Affected title branded and salvaged vehicles are eligible for this recall.

RELATED DAMAGE

If a related damage condition exists that you believe to be caused by the covered condition, call the Special Service Support Center to request approval **prior** to the repair of any related damage. Requests for approval after completion of the repair will not be granted. Ford Motor Company reserves the right to deny coverage for related damage in cases where the vehicle owner has not had this recall performed on a timely basis.

ADDITIONAL LABOR TIME

- If a condition exists that requires additional labor to complete the repair, call the Special Service Support Center to request approval **prior** to performing any additional labor. Requests for approval after completion of the repair will not be granted.
- If you encounter aftermarket equipment or modifications to the vehicle which might prevent the repair of the covered condition, call the Special Service Support Center.

Safety Recall 13S01

Certain 2004 - 2007 Model Year Freestar and Monterey Vehicles Operated in Corrosion States
3rd Row Seat Latch Striker Corrosion Repair

OWNER REFUNDS

- **This safety recall must still be performed, even if the owner has paid for a previous repair. Claiming a refund will not close the recall on the vehicle.**
- Ford Motor Company is offering a refund for owner-paid repairs covered by this recall if the repair was performed prior to the date indicated in the reimbursement plan, which is posted with this bulletin. Owners are directed to seek reimbursement through authorized dealers or, at their option, directly through Ford Motor Company at P.O. Box 6251, Dearborn, MI 48121-6251.
- Dealers are also authorized to refund owner-paid emergency repairs that were performed away from an authorized servicing dealer after the end date specified in the reimbursement plan. Non-covered repairs, or those judged by Ford to be excessive, will not be reimbursed.
- Refunds will only be provided for the cost associated with repair of 3rd row seat latch striker due to corrosion damage.

RENTAL VEHICLES

The use of rental vehicles is not authorized for this program.

CLAIMS PREPARATION AND SUBMISSION

- Enter claims using Direct Warranty Entry (DWE).
- Refer to ACESII manual for claims preparation and submission information.
- Related damage must be claimed on a repair line that is separate from the repair line on which the FSA is claimed. Related damage requires prior approval from the Special Service Support Center.
- "MT" labor should be submitted on a separate repair line with the related damage flag checked. "MT" labor requires prior approval from the Special Service Support Center.
- Submit refunds on a separate repair line.
 - Program Code: 13S01
 - Misc. Expense: ADMIN
 - Misc. Expense: REFUND
 - Misc. Expense: 0.2 Hrs.
- Multiple refunds should be submitted on one repair line and the invoice details for each repair should be detailed in the comments section of the claim.
- **Provision for Locally Procured Supplies:** Includes specified urethane sealer, undercoating, and up to two zip ties. Submit on the same repair line as the repair.
 - Program Code: 13S01
 - Misc. Expense: OTHER
 - Misc. Expense: Claim Actual Cost up to \$42.00

Safety Recall 13S01
Certain 2004 - 2007 Model Year Freestar and Monterey Vehicles Operated in Corrosion States
3rd Row Seat Latch Striker Corrosion Repair

LABOR ALLOWANCES

Description	Labor Operation	Labor Time
Install 3 rd row seat latch striker corrosion repair kit	13S01B	3.1 Hours

PARTS REQUIREMENTS / ORDERING INFORMATION

Part Number	Description	Quantity
4F2Z-1662418-A	3 rd Row Seat Latch Striker Corrosion Repair Kit	1
PM-4-A	Motorcraft Metal Brake Parts Cleaner (Aerosol)	1
WA-14-SBA ^{a/}	Zip Ties (can also use equivalent outside part ^{c/})	2
Urethane Seam Sealer - Black ^{b/ c/} (Procure Locally)	3M #08367 Urethane Seam Sealer (10.5 Oz. Tube) OR Lord Fusor #803EZ or #805HD Urethane Sealant (10.5 Oz. Tube)	1
Undercoating ^{b/ c/} (Procure Locally)	VALUGARD #VG104AEA Aerosol Undercoat (Aerosol) OR 3M #08883 Rubberized Undercoating (Aerosol)	1

a/ This part # includes 50 zip ties. Two are needed per repair.

b/ Chemicals have a shelf life/expiration date. Use only current, non-expired products for proper repair results.

c/ Claim as MISC OTHER. See Attachment I (CLAIMS PREPARATION AND SUBMISSION).
The DOR/COR number for this recall is 50495.

One-time Seed Stock

To ensure parts are available at dealers prior to owner notification, there will be a one-time seed stock of repair kit part number 4F2Z-1662418-A during the week of March 18, 2013.

Dealer Affected Vehicles	Seed Stock # of Kits Provided
1 to 19	1 Kit
20 to 49	5 Kits
50 to 99	10 Kits
100 & up	20 Kits

Safety Recall 13S01

Certain 2004 - 2007 Model Year Freestar and Monterey Vehicles Operated in Corrosion States
3rd Row Seat Latch Striker Corrosion Repair

PARTS REQUIREMENTS / ORDERING INFORMATION (Continued)

Dealers will need to access <https://web.fsavinlists.dealerconnection.com> to determine the total number of affected vehicles assigned to their dealership in order to calculate the number of parts that they will receive under the Seed Stock Program.

NOTE: Additional 3rd Row Seat Latch Striker Corrosion Repair Kits may be ordered by contacting the Special Service Support Center parts order line at 1-800-207-2444. Please be prepared to provide the dealer P&A code, VIN, RO# and customer name.

Dealers will be notified via a DOES II communication if circumstances warrant a change in part supply strategy and when open ordering begins.

Questions regarding parts should be directed to the Special Service Support Center Parts Order Line (1-800-207-2444) or E-mailed to: Ford@Renkim.com.

DEALER PRICE

For latest prices, refer to DOES II.

PARTS RETENTION AND RETURN

Follow the provisions of the Warranty and Policy Manual for "Parts Retention and Return Procedures."

EXCESS STOCK RETURN

Excess stock returned for credit must have been purchased from Ford Customer Service Division in accordance with Policy Procedure Bulletin 4000.

CERTAIN 2004 THROUGH 2007 MODEL YEAR FREESTAR AND MONTEREY VEHICLES OPERATED IN CORROSION STATES — 3RD ROW SEAT LATCH STRIKER CORROSION REPAIR

OVERVIEW

In some of the affected vehicles that are operated in high corrosion areas for an extended period, the sheet metal that supports the folding 3rd row seat latch strikers could experience corrosion and may compromise the mounting point for the forward portion of the 3rd row seat. Initially, this condition may result in seat movement when passengers sit on or put weight on the seat, or difficulty latching the front of the seat when in its seating position. If corrosion is severe, the seat latch strikers may become detached from the vehicle. The seat belts and the permanent mounting attachment at the rear of the seat are unaffected.

Dealers are to install *new* 3rd row seat latch striker mounting brackets which will re-locate the seat latch strikers away from the potentially corroded area. In addition, dealers are to install overlay panels in the exterior of the wheel wells to prevent the entry of water and corrosive elements. See 3rd Row Seat Latch Striker Corrosion Repair Kit components (below). This service must be performed on all affected vehicles at no charge to the vehicle owner.

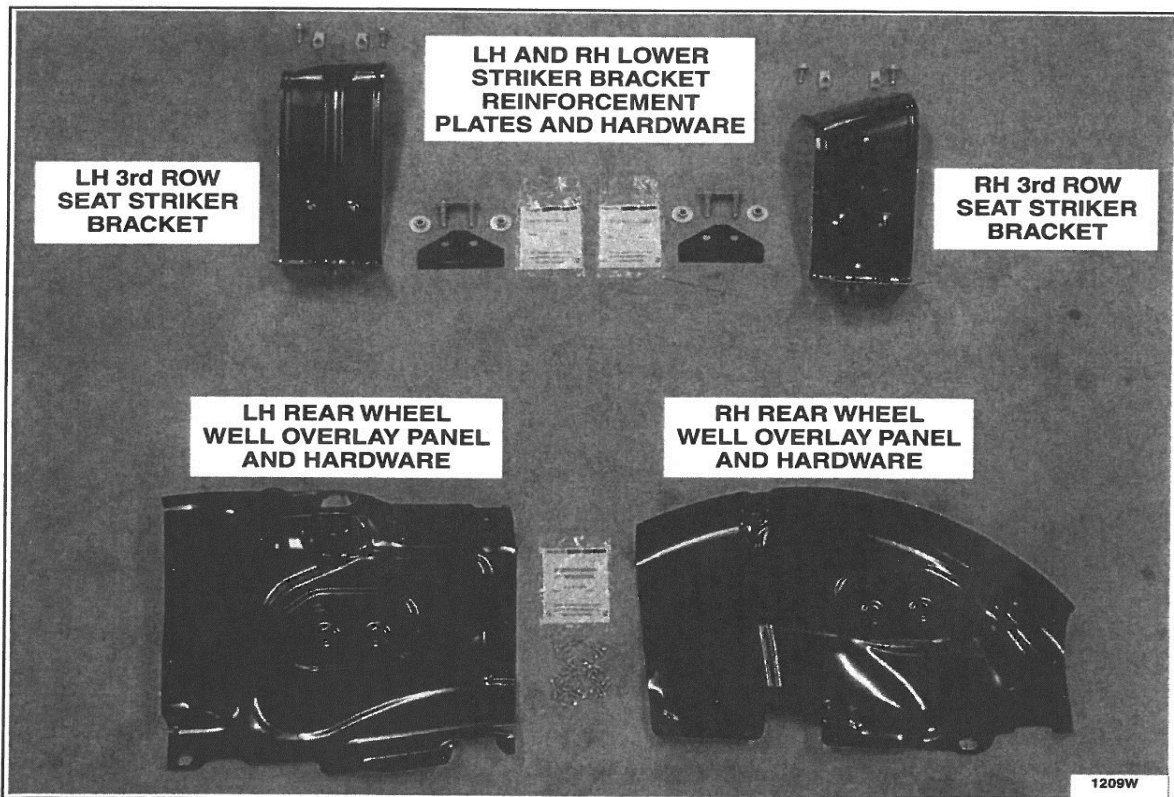

CPR © 2013 FORD MOTOR COMPANY
DEARBORN, MICHIGAN 48121
3/2013

SERVICE PROCEDURE

1. With the vehicle in NEUTRAL, position it on a hoist. For additional information, refer to Workshop Manual (WSM) Section 100-02.
2. Disconnect the battery cable to ground. For additional information, refer to WSM Section 414-01.
3. Note the position of the customer's 2nd and 3rd row seats, so they can be returned to that position after the repair.
4. If in the stowed position, raise the 3rd row seat out of the floor.
5. Remove 3rd row seat plastic floor trim panel. See Figure 1.
 - Use care not to damage mounting tabs. See Figure 1.

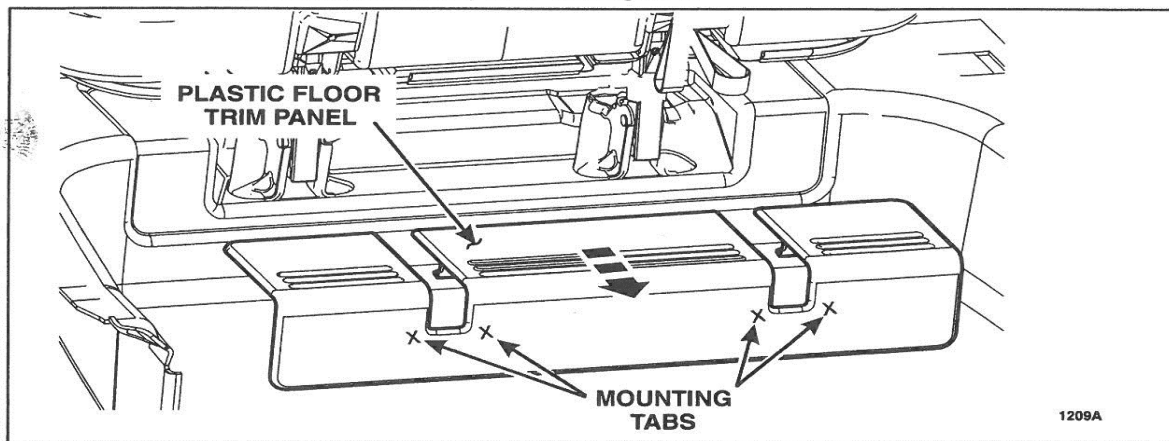

FIGURE 1



6. Position/remove the 2nd and 3rd row seat(s), as follows:
 - a. Place the 3rd row seat into the stowed position.
 - b. If equipped with 2nd row captains chairs, position the seats into the fold flat/forward cargo position.
 - c. If equipped with a 2nd row bench seat, remove the seat from the vehicle.
7. Remove the RH and LH rear quarter trim panels. For additional information, refer to WSM Section 501-05.
8. If equipped, remove LH heating duct. See Figure 2.
 - a. Remove the two bolts, two scrivenets, and the nut.
 - b. Position the heating duct aside and detach the wire harness retainer and the electrical connector.
 - c. Remove the LH heating duct.

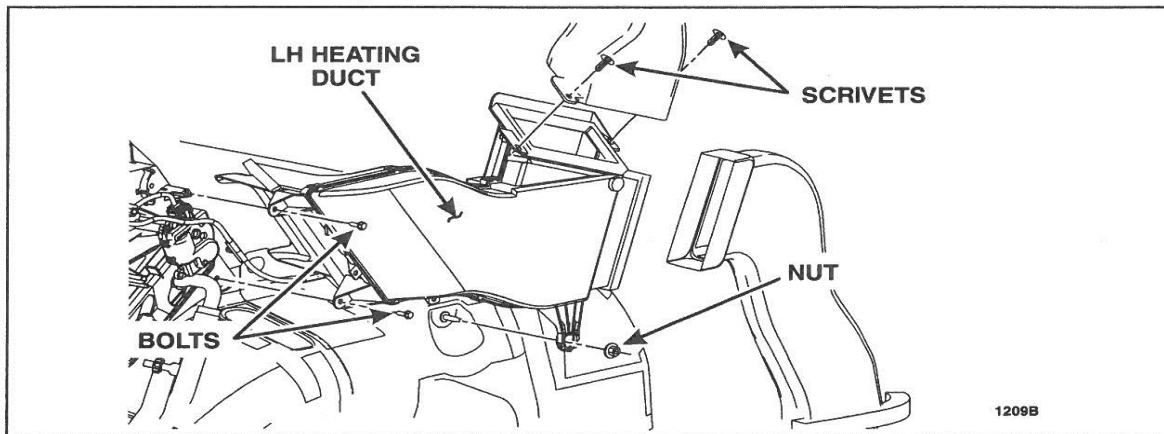

FIGURE 2



NOTICE: The wiring harness must be positioned up and off the wheel well and toward the side of the vehicle to prevent damage by sheet metal screws that will be installed later in the procedure.

9. Reposition the LH wheel well wire harness. See Figure 3.

- a. Remove the bolt from the LH liftgate module. Detach the clip and slide the module forward to position aside.
- b. Remove the wire harness from the retainers.
- c. Secure the wire harness to the speaker bracket with a zip tie.
- d. Position the LH liftgate module back onto the mounting bracket with the wiring harness positioned on top of the module. Install the bolt (do not over tighten).

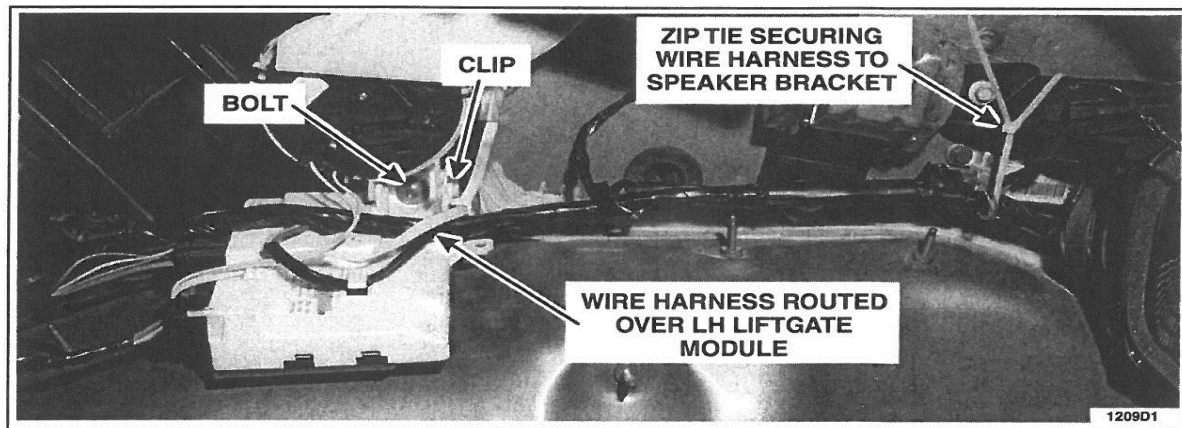

FIGURE 3



NOTICE: The wiring harness must be positioned up and off the wheel well and toward the side of the vehicle to prevent damage by sheet metal screws that will be installed later in the procedure.

10. Position aside the RH wheel well wire harness. See Figure 4.
 - a. Remove the three RH speaker bolts and position the RH speaker aside.
 - b. Remove the wire harness from the retainers.
 - c. Secure the wire harness to the seat belt retractor bracket with a zip tie.
 - d. Reposition the wire harness behind the speaker tab and install the three bolts (do not over tighten).

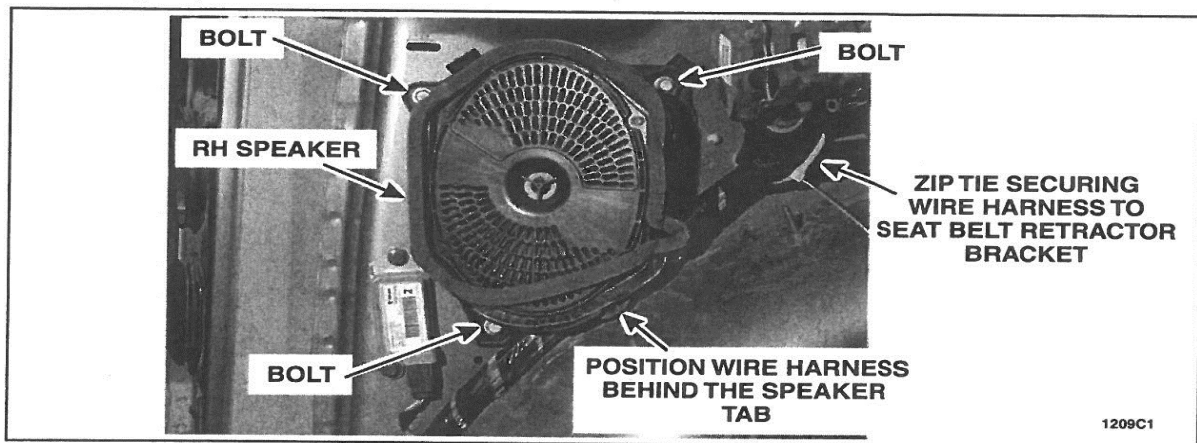

FIGURE 4

11. Position the carpet away from the RH and LH wheel wells.
12. Cover the carpet to protect it while performing any cutting, drilling, or grinding.



13. Note the orientation of the RH and LH 3rd row seat strikers. The top of the strikers are marked with "UP" for installation reference. Remove the two nuts and the 3rd row seat strikers from the RH and LH wheel wells. See Figure 5.

- Do not discard the nuts or 3rd row seat strikers, they will be used during reassembly.

NOTE: LH side shown, RH side similar.

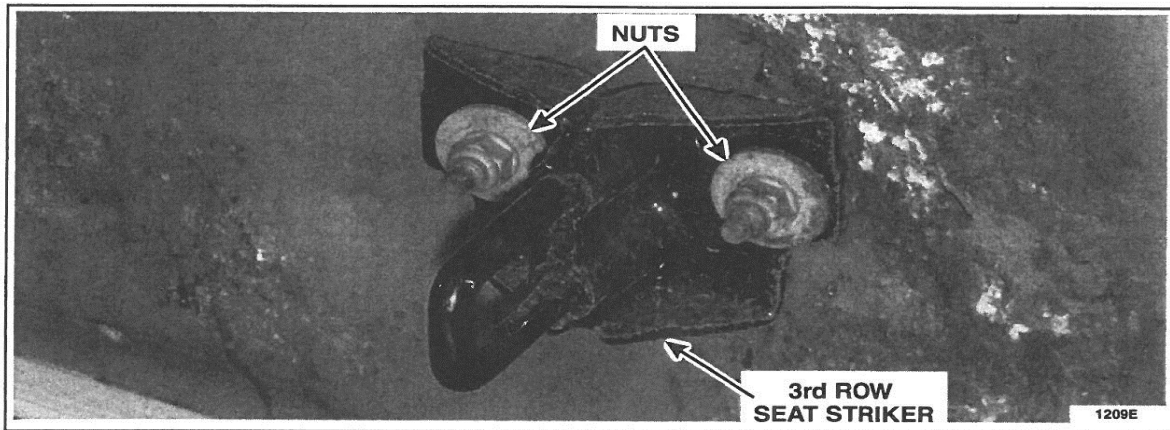

FIGURE 5

14. Using a suitable angle grinder, cut off the RH and LH 3rd row seat striker mounting studs (four total, 2 each side), flush with the wheel well panel. See Figure 6.

NOTE: LH side shown, RH side similar.

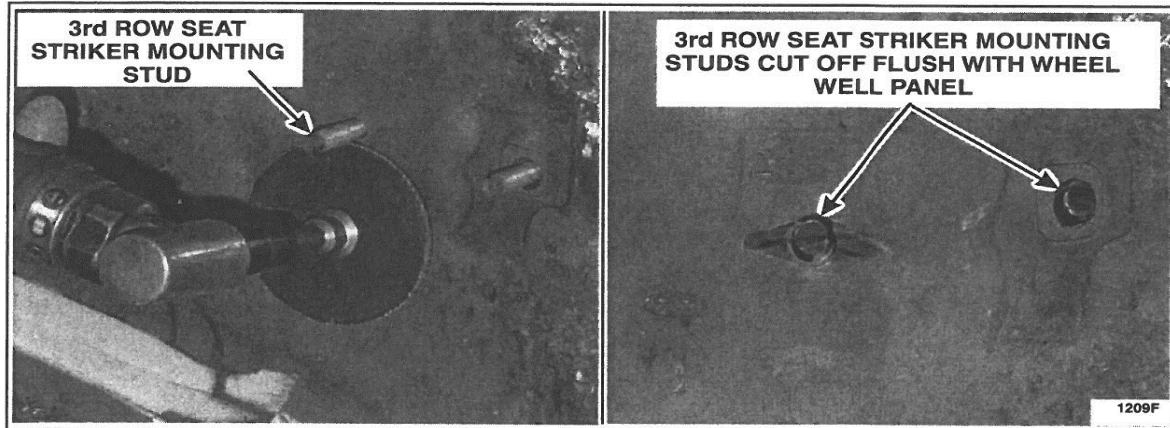

FIGURE 6



15. By using the contour of the original wheel well panel and the location of the original 3rd row seat striker studs as a guide, place the *new* RH and LH 3rd row seat striker brackets into their approximate positions on each side of the vehicle. Scribe the perimeter of the brackets on floor. See Figure 7.

NOTE: LH side shown, RH side similar.

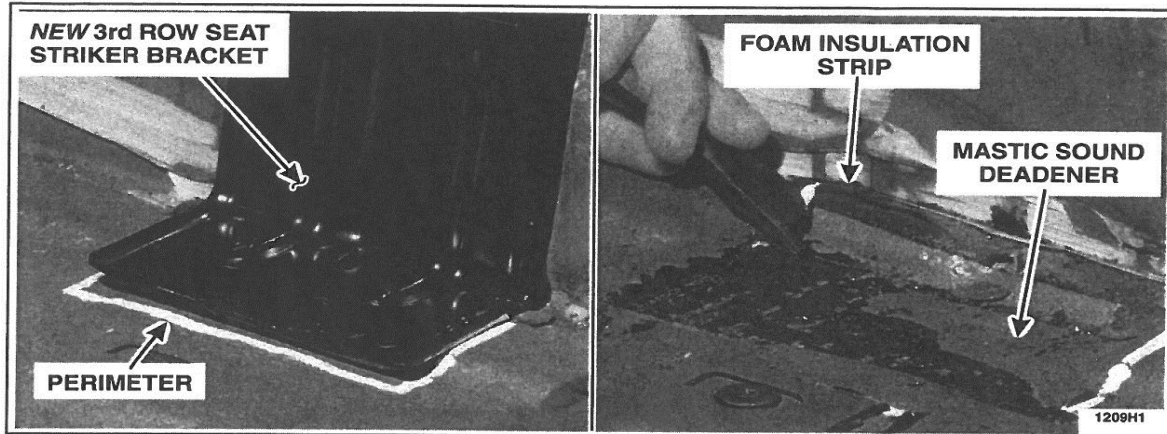

FIGURE 7

16. Use a suitable chisel or gasket remover to remove the mastic sound deadener and foam insulation strip from the floor, in the areas where the *new* RH and LH 3rd row seat striker brackets will attach to the floor. See Figure 7.
- Make sure enough material is removed to allow the bracket to sit directly on the floor sheet metal and not on top of the mastic sound deadener.
 - Use caution not to penetrate through the floor sheet metal.
 - Use a suitable shop vacuum to clean up the material that was removed.



17. Position the *new* RH and LH 3rd row seat striker brackets back into the mounting position. Ensure that the locating tab on the striker bracket fits into the existing locating hole in the floor panel. See Figure 8.

NOTE: It is important to position the back of the *new* RH and LH 3rd row seat striker brackets so they fit tight against the existing wheel wells to provide proper clearance for the seat latch hardware. If necessary, bend the locating tab slightly to achieve proper fit/position of the brackets. See Figures 8 and 9.

18. Mark and center-punch the four (two each side) attachment bolt hole locations on the floor. See Figure 8.

NOTE: LH side shown, RH side similar.

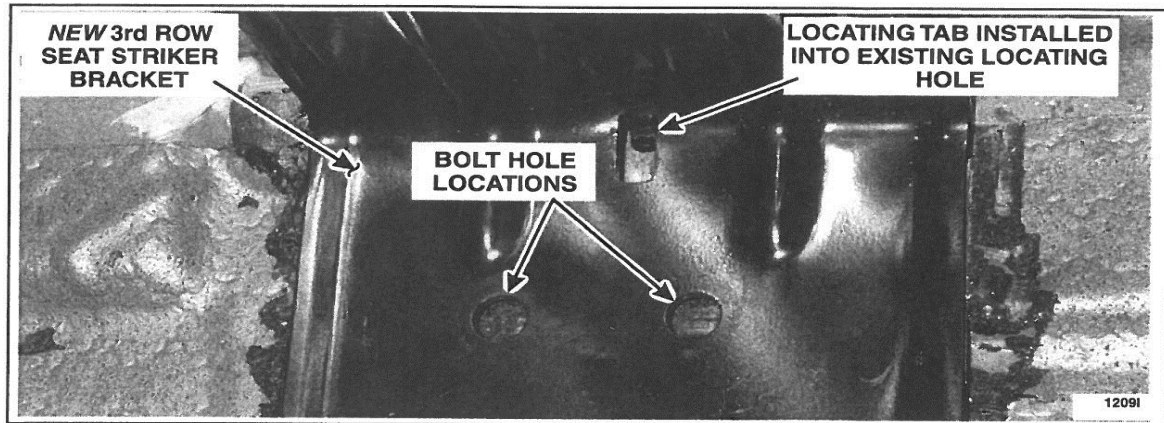

FIGURE 8

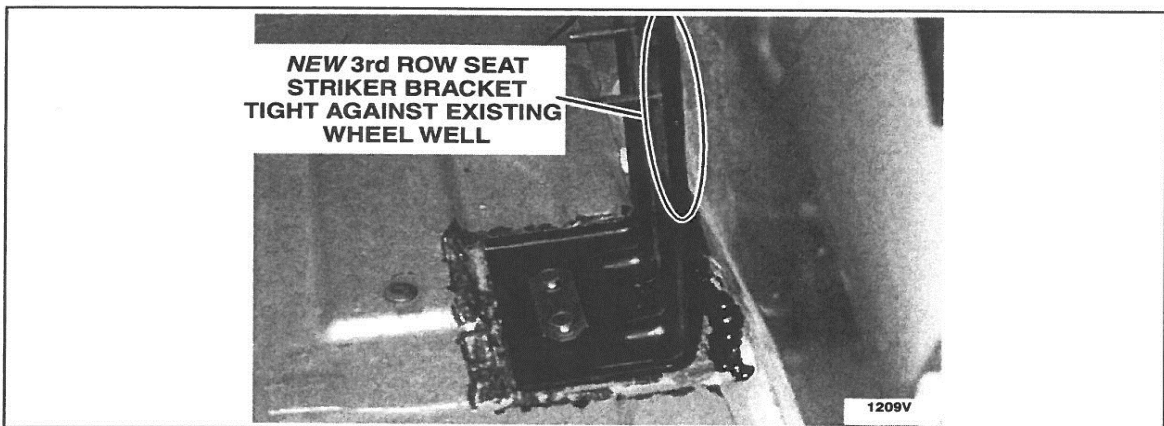

FIGURE 9



19. Position the *new* 3rd row seat striker brackets aside and drill four 12.7 mm (1/2 in) holes at the four locations (two each side) marked in Step 18.
 - Use a suitable shop vacuum to clean the metal shavings.
 - Apply a light application of undercoating to the drilled holes.
20. Raise the vehicle.
21. Remove both rear wheel and tire assemblies. For additional information, refer to WSM Section 204-04.
22. Remove three screws, 2 pin-type retainers and the LH rear wheel well inner splash shield.
23. Place the *new* RH and LH rear wheel well overlay panels into position. Use a suitable paint pen to mark the position around the perimeter of the panels on the surface of the wheel wells. See Figure 10.
 - The rear wheel overlay panels should fit tight into the radius of the original panel. The features along the lower edge of the *new* panel should match up to the features of the original panel. It is important the panels fit tight against the existing sheet metal for proper sealing.

NOTE: LH side shown, RH side similar.

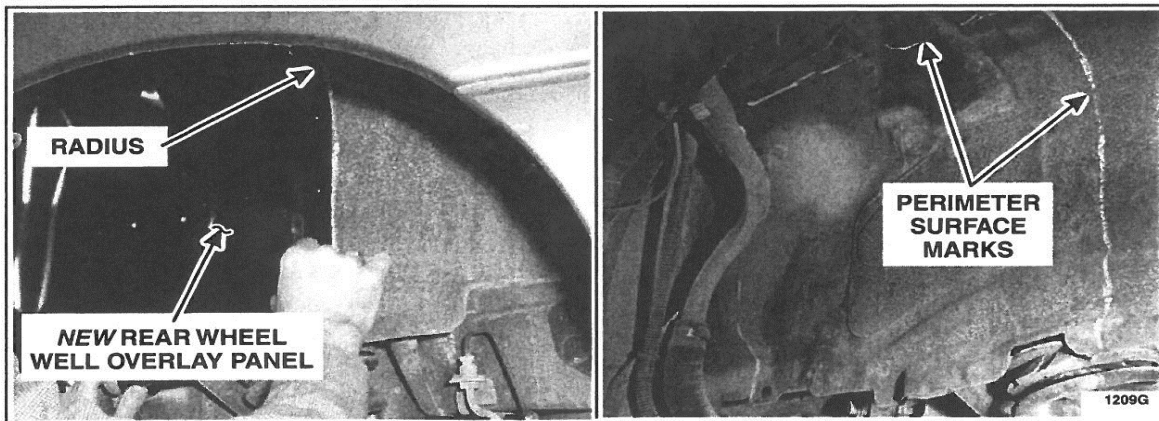

FIGURE 10



26. Perform a final cleaning of the original RH and LH wheel well undercoating surface:

- Spray the wheel well surface using Motorcraft® Metal Brake Parts Cleaner, or equivalent to remove any material that may have been loosened.
- Using compressed air blow off any additional loose material and dry the wheel well surface.

27. Using Motorcraft® Metal Brake Parts Cleaner, clean the *new* RH and LH wheel well overlay panels, in the areas where urethane seam sealer will be applied. See Figure 13.

NOTE: Complete the LH wheel well overlay panel installation prior to starting installation on the RH wheel well overlay panel, this should be done to prevent the urethane seam sealer from curing before the overlay panel is installed.

28. Apply a continuous 9.4 mm (3/8 in) bead of urethane seam sealer around the outer edge of the *new* LH wheel well overlay panel. Apply additional sealer to the notched out area on the bottom of the overlay panel and apply a bead around the dimples in the center of the panel. See Figure 13.

NOTE: LH side shown, RH side similar.

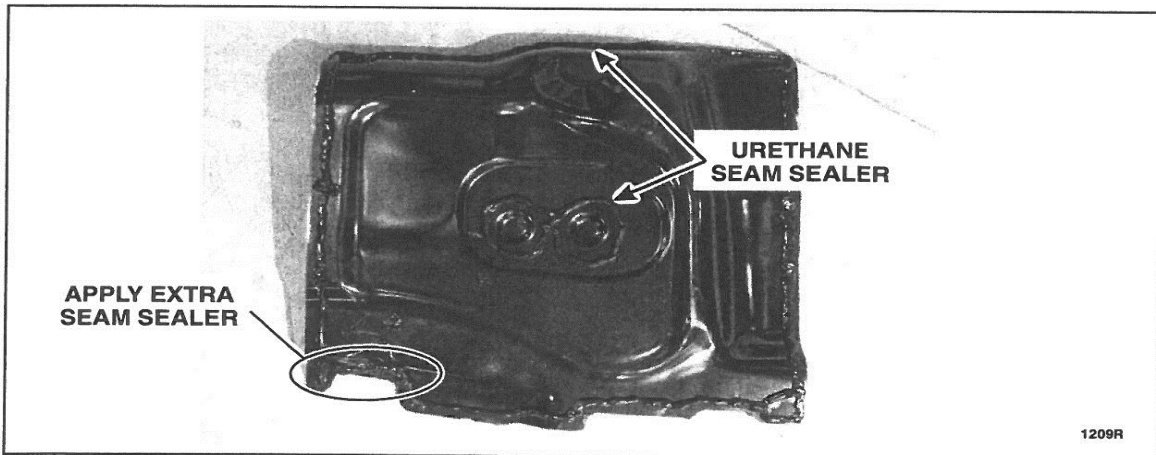

FIGURE 13



29. Place the *new* LH wheel well overlay panel in position and press it into the original panel.
Align the *new* panel to fit tightly into the original wheel well radius so that the features of the panels match. See Figure 14.
- Press the panel tightly around the perimeter to squeeze the urethane between the panels.
 - Use a ball-peen hammer and tap lightly, if necessary, to help the *new* panel conform to the original.
 - Use suitable Vise-Grips® to hold the panel in position at the bottom.

NOTE: LH side shown, RH side similar.

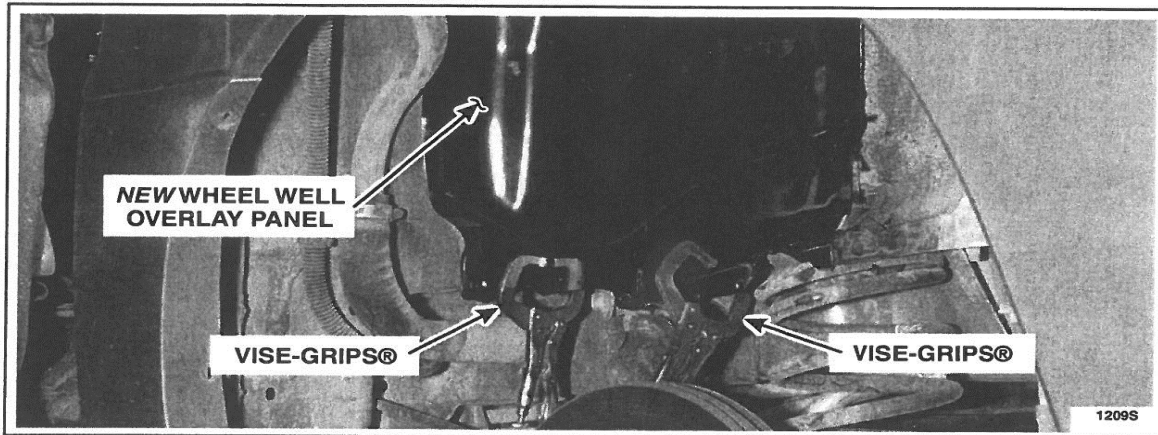

FIGURE 14



30. Using the self-tapping screws, secure the *new* LH overlay panel to the original panel in the order shown in Figure 15. Use care not to over-tighten and strip the screw attachments.

NOTE: To ensure a tight fit to the original panels, it is important to install the screws in the order shown in Figure 15.

- a. Install screw at locations marked as "1".
- b. Press the panel firmly into the radius area, use a ball-peen hammer if necessary to draw panels together, and install screws at locations marked "2".
- c. Install screws at locations marked "3". Remove Vise-Grips®.
- d. Install screws at locations marked "4" and then "5".

NOTE: A pilot hole may be required before installing the self-tapping screws in areas where spot welds exist. The spot welds are located mostly along the bottom edge of the wheel wells.

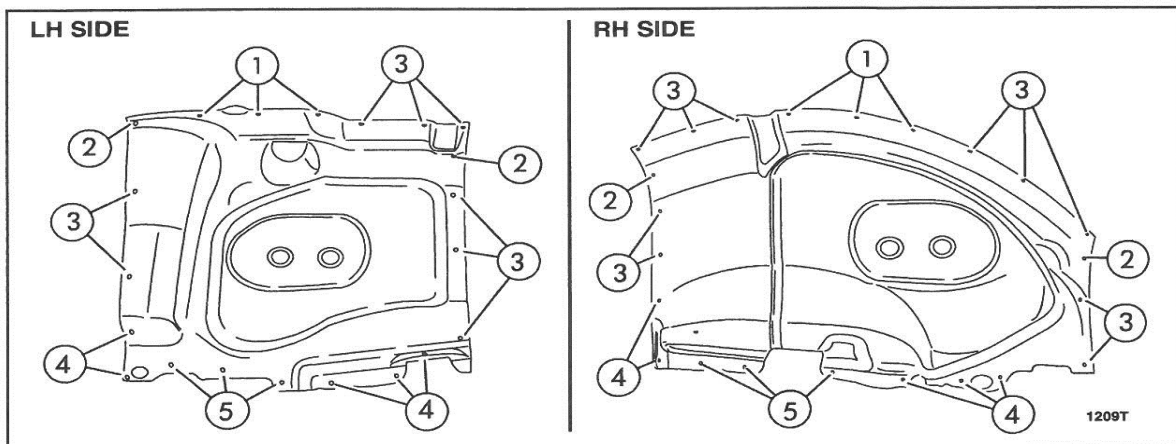

FIGURE 15

31. Using a suitable putty knife, apply urethane seam sealer, over each of the self-tapping screw heads and in any areas where sealer did not seal the perimeter.

32. Repeat Steps 28-31 for the RH side.

33. Lower the vehicle.



34. Working from inside the vehicle, inspect the position of the installed self-tapping screws. Use a suitable angle grinder to cut off the ends of the self-tapping screws that will interfere with installation of the *new* 3rd row seat striker bracket upper attachment (See Figure 16) or with the mounting of any modules, wire harnesses or trim panels.

NOTE: LH side shown, RH side similar.

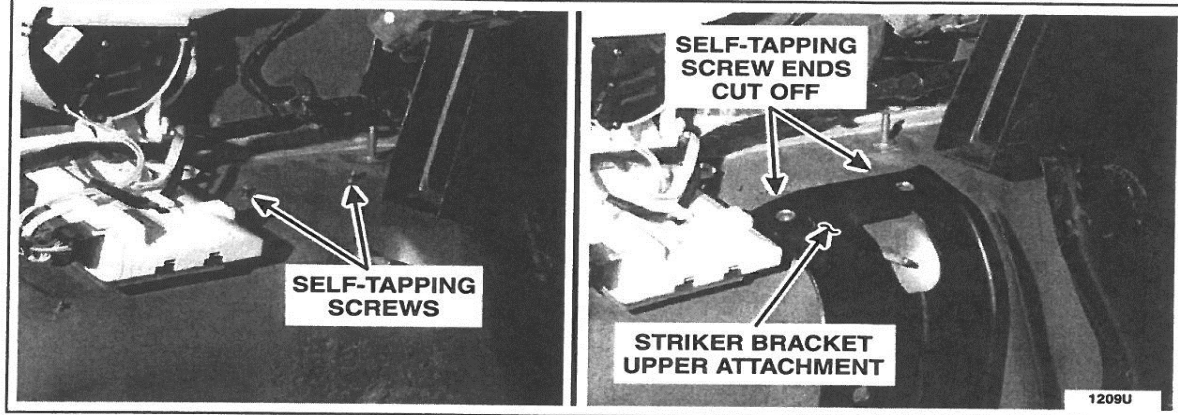

FIGURE 16

35. Clean the wheel well to floor panel seam in the area where the *new* RH and LH 3rd row seat striker brackets will be installed. Apply a bead of urethane seam sealer to the seam and to the existing bracket locating hole. See Figure 17.

NOTE: LH side shown, RH side similar.

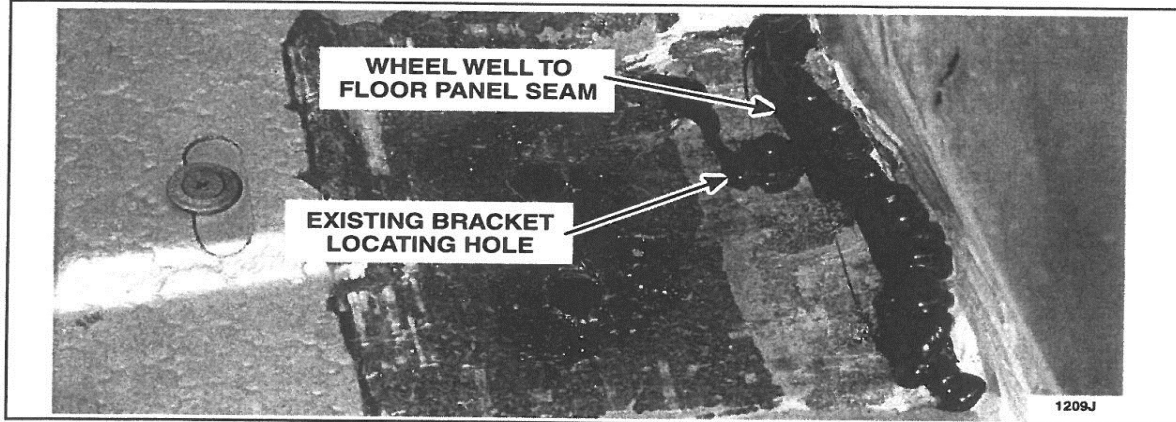

FIGURE 17



36. Place the *new* RH and LH 3rd row seat striker brackets in position. Make sure the bracket locating tab is engaged in the bracket locating hole and that the bracket is flush with the existing wheel well sheet metal. Install two (one each side) *new* ganged bolt assemblies through the holes on each side of the vehicle. See Figure 18.

NOTE: RH side shown, LH side similar.

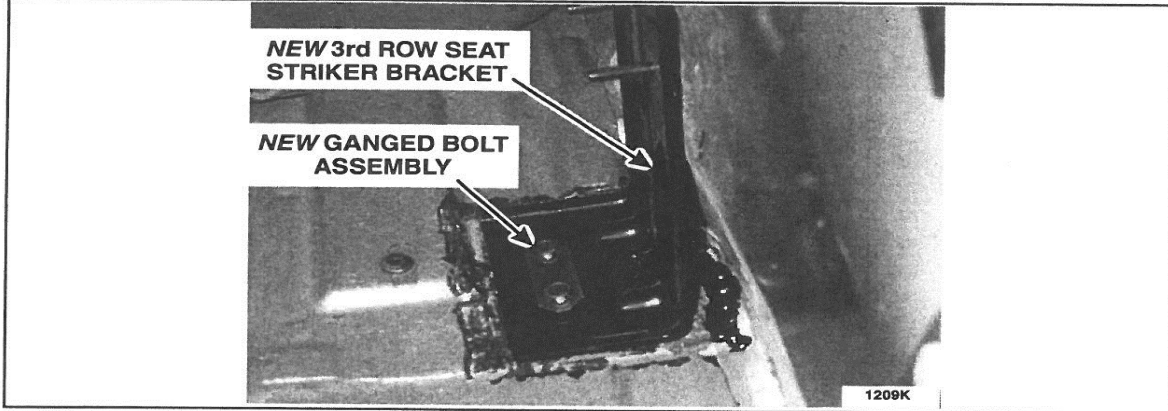

FIGURE 18

37. Position the *new* RH and LH lower striker bracket reinforcement plates and install two *new* nuts. See Figure 19.

- Use caution not to push the *new* ganged bolt assemblies out while installing the *new* reinforcement plates.
- Tighten to 62 Nm (46 lb-ft).

NOTE: RH side shown, LH side similar.

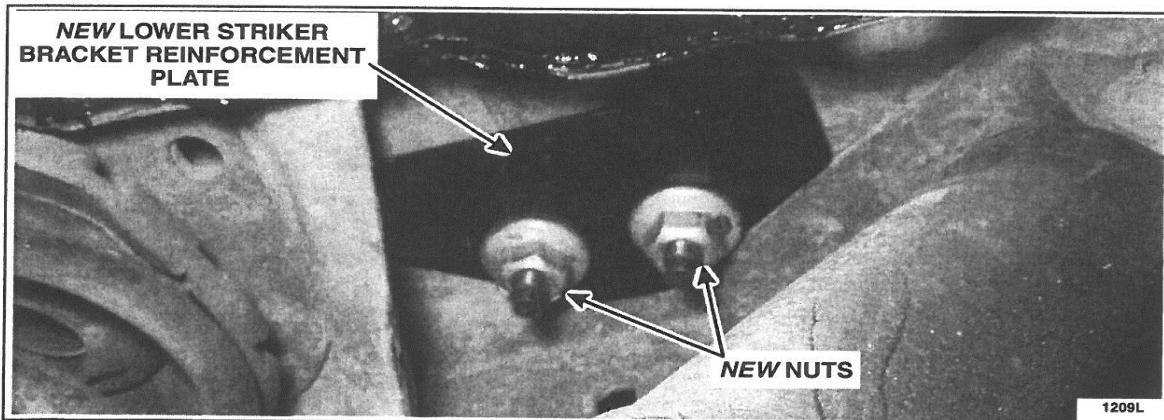

FIGURE 19



38. Hold the *new* RH and LH 3rd row seat striker brackets tight against the wheel wells. Center-punch and drill four (two per side) 9.525 mm (3/8 in) holes in the center of each of the 3rd row seat striker bracket upper mounting attachment locations. See Figure 20.

- Apply a light application of undercoating to the drilled holes.

NOTE: RH side shown, LH side similar.

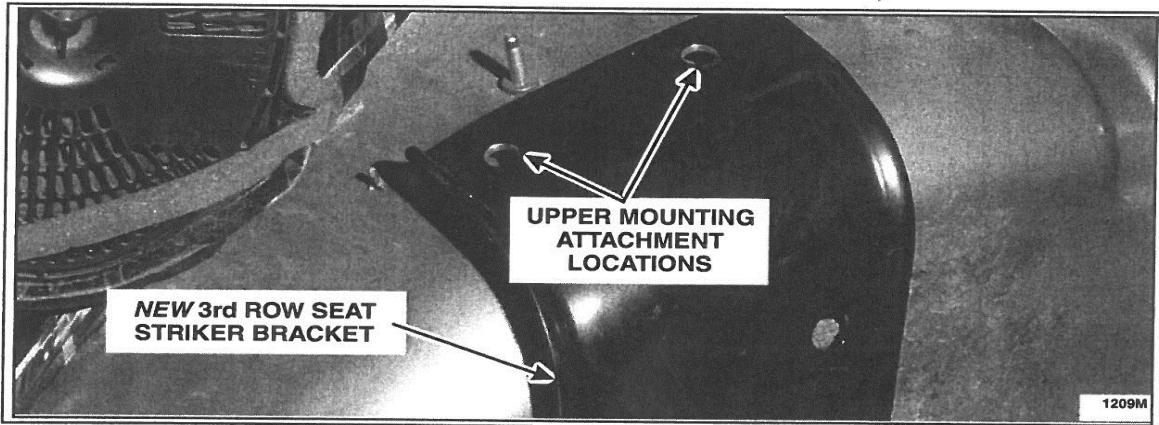

FIGURE 20

39. Slide the *new* J-nuts onto each of the four *new* RH and LH 3rd row seat striker bracket upper mounting attachment locations. See Figure 21.

NOTE: RH side shown, LH side similar.

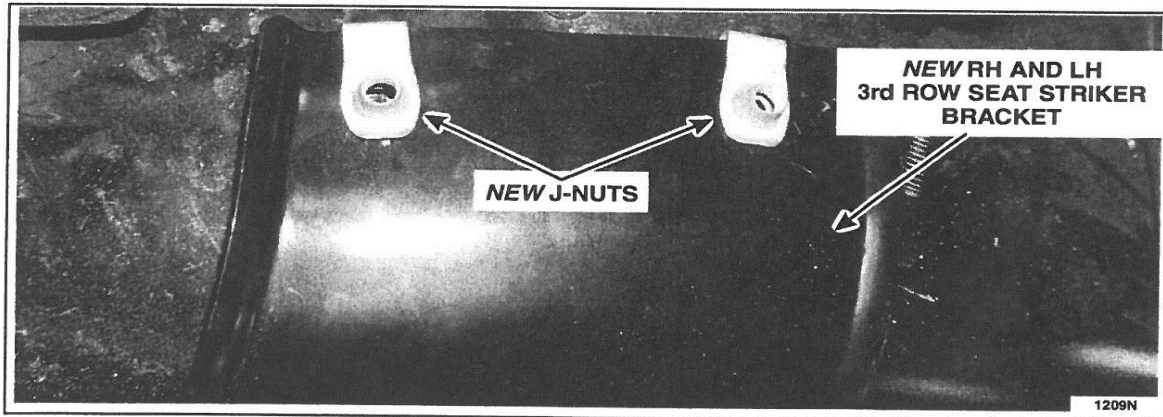

FIGURE 21



40. Raise the vehicle.
41. Install four (two per side) *new* 3rd row seat striker bracket upper mounting attachment bolts.
See Figure 22.
 - Tighten to 30 Nm (22 lb-ft).

NOTE: RH side shown, LH side similar.

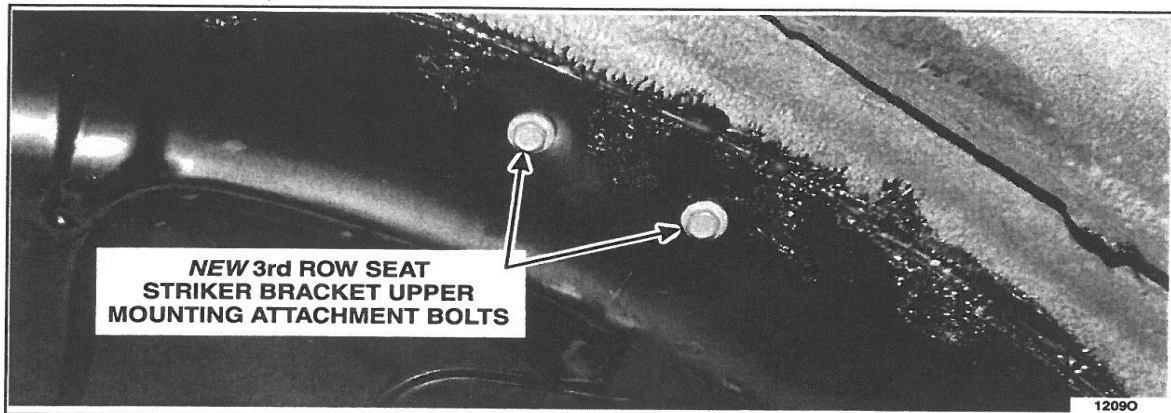

FIGURE 22

42. Spray the *new* overlay panels and the lower striker bracket reinforcement plates with one coat of undercoating.
43. Install the LH rear wheel well inner splash shield and 2 pin-type retainers. Install and tighten the three screws.
44. Install both rear wheel and tire assemblies. For additional information, refer to WSM Section 204-04.
45. Lower the vehicle.
46. Position the carpet back into its original position.
47. Install original 3rd row seat strikers onto the studs of the *new* 3rd row seat striker brackets, using original nuts.
 - a. Make sure the strikers are installed in their original orientation. The top of the strikers are marked with "UP" for installation reference. See Figure 5.
 - b. Use the alignment marks that are stamped into the bracket to help align the strikers before tightening fully.
 - c. Tighten to 20 Nm (15 lb-ft).



48. If equipped, install LH heating duct. See Figure 2.
 - a. Install the heating duct.
 - b. Connect the wire harness retainer and the electrical connector.
 - c. Install the two bolts, two scrivenets, and the nut.
 49. Install the RH and LH rear quarter trim panels. For additional information, refer to WSM Section 501-05.
 50. Operate the 3rd row seat to check the 3rd row seat latch striker for correct adjustment. Adjust horizontally and vertically, as needed. To adjust:
 - a. Remove the striker trim cover(s) from the quarter trim panel.
 - b. Loosen the 2 nuts enough to allow movement of the striker.
 - c. Gently lower the 3rd row seat down to the striker and align the striker to the latch.
 - d. Tighten the nuts.
 - e. Tighten to 20 Nm (15 lb-ft).
 - f. Make sure both 3rd row seat latches latch fully and evenly to the strikers. Reinstall striker covers when complete.
- NOTE:** If the seat is not centered on the strikers, loosen the four nuts that secure the seat to the floor hinge and reposition as necessary. Once centered, tighten the seat hinge nuts to 55 Nm (41 lb-ft).
51. Position the 2nd and 3rd row seats back to the customer's initial position.
 52. Install the 3rd row seat plastic floor trim panel. See Figure 1.
 - Use care not to damage mounting tabs. See Figure 1.
 53. Connect the battery cable to ground. For additional information, refer to WSM Section 414-01.
 54. Return vehicle to customer.

